

**Municipal Minnesota
Interconnection Process (M-MIP)**

PROCESS OVERVIEW

Booklet #1

Provided to all interconnection inquirers

Contents

Foreword	1
1 Key Terminology	2
1.1. Distributed Energy Resource	2
1.2. Point of Common Coupling (PCC) / Point of DER Connection (POC).....	2
1.3. Capacity	2
1.4. Technical Requirements.....	3
2 Roles	3
2.1. Overview.....	3
2.2. DER Interconnection Coordinator	3
2.3. Interconnection Customer	3
2.4. Application Agent	4
2.5. Engineering Roles	4
3 Processes	4
3.1. Overview.....	4
3.2. Importance of Process Timelines	5
3.3. Simplified Process.....	6
3.4. Fast Track Process	6
3.5. Study Process.....	7
3.6. Process Assistance	7
4 Interconnection Application	7
4.1. Overview.....	7
4.2. Availability of Information	8
4.3. Interconnection Application Process Fees	8
4.4. Application Review Timelines.....	8
4.5. Comparability.....	9
4.6. Changing Process Queues	9
4.7. Queue Position	10
4.8. Site Control.....	10
5 Pre-Application Report	10
5.1. Pre-Application Report Requests	10
5.2. Information Provided	11
5.3. Pre-Application Report Components	11
6 Capacity of the Distributed Energy Resources	12
6.1. Existing DER System Expansion	12

6.2.	New DER Systems	12
6.3.	Limited Capacity	13
6.4.	Acceptable Methods for Establishing Capacity Rating of a DER System.....	13
6.5.	Acceptable Methods for Establishing Export Capacity of a DER System.....	13
6.6.	Area EPS Operator Approval of Modified Capacity.....	14
7	Modification to Interconnection Applications.....	14
7.1.	Procedures.....	14
8	Interconnection Agreements	15
8.1.	Timelines.....	15
8.2.	Types of Agreements.....	15
9	Interconnection	16
9.1.	Metering.....	16
9.2.	Inspection, Testing and Commissioning	16
9.3.	Interconnection Costs.....	17
9.4.	Technical Requirements.....	17
9.5.	Authorization for Parallel Operations.....	18
9.6.	Non-Compliance with Agreements.....	18
10	Extension of Timelines	18
10.1.	Reasonable Efforts	18
10.2.	Extensions	18
11	Disputes.....	19
11.1.	Procedures	19
12	Clauses	19
12.1.	Confidentiality.....	19
12.2.	Non-Warranty	20
12.3.	Indemnification	20
12.4.	Limitation of Liability	21
13	Glossary.....	22
14	Certification of DER Equipment	27
15	Interconnection Process Milestones.....	28

Foreword

The State of Minnesota currently has interconnection process standards in effect to address the interconnection of distributed energy resources (DER) to the distribution grid. Under Minnesota Statute §216B.1611, cooperatives and municipals shall adopt an interconnection process that addresses the same issues as the interconnection process approved by the Minnesota Public Utilities Commission. The Municipal Minnesota Interconnection Process (Interconnection Process or M-MIP) applies to any DER no larger than 10-megawatts (MW) AC interconnecting to and operating in parallel with the electric distribution system of a municipal utility that has adopted the M-MIP for use. This interconnection process document is designed to be customer-centric when explaining the steps and details to interconnect DER systems to the distribution grid.

The Interconnection Process is comprised of five booklets: 1) Process Overview; 2) Simplified Process; 3) Fast Track Process; 4) Study Process; and 5) Non-Export Process and also contains several forms, including a final Interconnection Agreement. For the majority of DER interconnections, only the Process Overview and the Simplified Process manuals will apply. For larger and more complex DER interconnections, the Fast Track Process or the Study Process may apply.

As part of the Interconnection Process, an Interconnection Agreement is to be executed prior to interconnecting a DER system to the utility distribution grid. For most DER interconnections, the utility's Contract for Cogeneration and Small Power Production Facilities (Uniform Contract) will be used. For DER systems that do not fall under the terms of the Uniform Contract, the Municipal Minnesota Interconnection Agreement (MMIA) will apply.

The process to interconnect a DER system to the distribution grid starts with the submission of an Interconnection Application. Each track has different information that is requested in the application and the non-refundable interconnection application fees will vary. Both the electric utility and the interconnecting customer have timelines that are enforced to ensure a timely application review, contract execution and interconnection commissioning.

The key to a successful interconnection of a DER system is communication between all parties. Timely submission of the Interconnection Application prior to the purchase and installation of a DER system is strongly recommended. The utility encourages customers to ask questions throughout the interconnection process. Interconnecting DER system to the distribution grid is not an effortless process, but it does not need to be a problematic process either.

Key Terminology

1.1. Distributed Energy Resource

Distributed Energy Resources, DER, were often referred to in past interconnection processes as Distributed Generation, DG, and on occasion also interchanged with the term Qualifying Facility, QF. This Interconnection Process uses the term DER to address all types of generation and energy resources that can be interconnected to the electric Distribution System. DER technologies can include photovoltaic solar systems, wind turbines, electric storage batteries, electric vehicles or diesel generators and are not limited to renewable types of technologies.

1.2. Point of Common Coupling (PCC) / Point of DER Connection (POC)

DER systems often reside behind the utility's revenue meter of a residence or business. The meter is normally the point of demarcation between the utility-owned equipment and the customer-owned equipment. The term Point of Common Coupling, PCC, is the demarcation location between the utility and the customer.

The Point of DER Connection, PoC, can be different from the PCC. The PoC is the location where a DER system would interconnect to the electrical system normally owned by the customer. For example, the PoC for a rooftop photovoltaic solar system may be the main electrical panel in a customer's home.

1.3. Capacity

Throughout the Interconnection Process will be references to the capacity of the DER system. The Capacity Rating of the DER system is used to determine the process track and is determined by the DER system capability to produce or release energy without taking into consideration customer's load. All capacity references will be in alternating current, AC.

There can be multiple DER systems, also called DER units, with different PoCs that all have the same PCC submitted on a single interconnection application. The capacity for this type of interconnection would be the aggregate Capacity Rating of all DER units at the individual PoCs. Additional examples of DER system arrangements can be seen in Section 13 under the definition of Point of Common Coupling. The aggregate Capacity Rating of all DER units can be different from the aggregate Nameplate Rating if the inverters are programmed to have an output less than Nameplate Rating or if a power control system (PCS) is used to manage DER output from the DER units.

1.4 Technical Requirements

The M-MIP often refers to state and local technical requirements. These are embodied in the Minnesota Technical Interconnection and Interoperability Requirements (TIIR) and the Area EPS Operator's Technical Specifications Manual (TSM) respectively.

2 Roles

2.1. Overview

During the interconnection process for a proposed DER system, there may be multiple entities involved in the application, approval and commissioning processes. The main entities that are involved during the Interconnection Process for a proposed DER system are the Interconnection Customer, the Application Agent and the DER Interconnection Coordinator. Official definitions of each entity are defined in the Glossary (Section 13). Additional details are explained in the subsections below.

2.2. DER Interconnection Coordinator

The utility is referred to as the Area Electric Power Supply Operator in this Interconnection Process. The Area EPS Operator shall designate a DER Interconnection Coordinator to serve as a single point of contact from which general information on the application process may be obtained. The DER Interconnection Coordinator shall be available to provide coordination assistance with the Interconnection Customer but is not responsible for directly answering or resolving all of the issues involved in review and implementation of the interconnection process and standards.

The contact information of the DER Interconnection Coordinator will be posted on the Area EPS Operator's website if feasible, or available from the utility.

2.3. Interconnection Customer

Under state law and municipal utility rules governing statutory and contractual rights and obligations related to qualifying, customer-owned, interconnected DERs, "customer" is defined as the person or entity named on the utility electric bill for the premises. The M-MIP defines "Interconnection Customer" as such a customer who owns and seeks to interconnect a DER on their premise with the Area EPS. The Interconnection Customer must sign applications and agreements prescribed by the M-MIP and is legally responsible under them. An Application Agent or engineer might fulfill other procedural roles prescribed to the Interconnection Customer. (See 2.4 and 2.5 below.) However, an Application Agent cannot take the place of the utility customer for purposes of DER ownership, nor be a seller of electrical output from a DER to a utility customer.

2.4. Application Agent

The Interconnection Customer may designate, on the Interconnection Application or in writing after the application has been submitted, an Application Agent to serve as a single point of contact to coordinate with the DER Interconnection Coordinator on their behalf. Designation of an Application Agent does not absolve the Interconnection Customer from signing application documents and the responsibilities outlined in the Interconnection Process or in interconnection agreements. DER vendors, project managers or electricians are common entities that the Interconnection Customer may designate to perform this role.

2.5. Engineering Roles

Either party may designate a specific person to be a single point of contact to provide technical expertise during the Interconnection Process for themselves or their organization. The person to supply engineering expertise may be a third party such as an engineering consultant or manufacturer's engineer.

3 Processes

3.1. Overview

This Interconnection Process applies to any DER no larger than 10 MW AC interconnecting to an Area EPS in Minnesota that has adopted the M-MIP. Interested parties with plans to interconnect DER systems larger than 10 MW AC to the Area EPS should contact the Area EPS Operator for a case-specific interconnection process. Federal Energy Regulatory Commission's (FERC) interconnection process will supersede any interconnection process the Area EPS Operator has for DER system interconnections that fall under the jurisdiction of FERC.

The Interconnection Process for DER is broken into four different tracks; the Simplified Process, the Fast Track Process, the Study Process and the Non-Export Process. The general classification of each track is summarized in Table 3.1 below.

Table 3.1. Interconnection Process Tracks

Track	DER Technology	Size Limitations
Simplified Process	Certified Inverter only	20 kW AC
Fast Track Process	All types	5 MW AC
Study Process	All types	10 MW AC
Non-Export Process	All types	100 kW

Figure 1. Interconnection Process Tracks

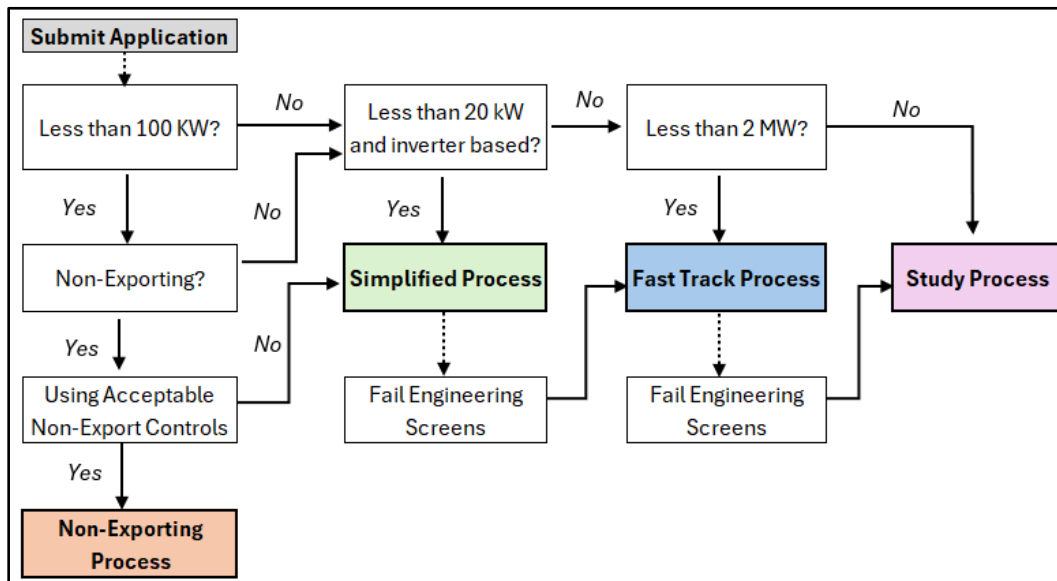

If engineering screens are failed during the application process, a proposed DER interconnection may be moved into a different track. When a proposed DER interconnection is moved into a different track, additional information may be requested, and additional fees may apply.

3.2. Importance of Process Timelines

It is very important to pay attention to timelines listed for each process track. The timelines exist for an orderly and efficient process to interconnect DER systems to the Area EPS. If a timeline is missed by an Interconnection Customer, without the Interconnection Customer requesting a Timeline Extension explained in Section 10, the Interconnection Application will be deemed withdrawn by the Area EPS Operator.

The Area EPS Operator also needs to abide by the timelines listed for each process track. The process for an Area EPS Operator to request Timeline Extensions is also addressed in Section 10.

Unless otherwise stated, all time frames are measured in Business Days. For purpose of measuring these time intervals, the time shall be computed so as to exclude the first and include the last day of the prescribed duration of time. Any communication sent or received after 4:30 p.m. Central Prevailing Time or on a Saturday, Sunday or Holiday shall be considered to be sent on the next Business Day

3.3. Simplified Process

An application to interconnect a certified¹, inverter-based DER system no larger than 20 kilowatts (kW) shall be evaluated under the Simplified Process. A common form of DER inverter certification is UL 1741-SB. DER systems that utilize a Power Control System (PCS) shall have the certification of UL 3141². Proposed DER systems that require Area EPS system modifications to accommodate the interconnection do not qualify for the Simplified Process. A transformer change, fusing upgrades or line extensions are common examples of Area EPS system modification. Simplified Process eligibility does not imply or indicate the Interconnection Application will pass the initial review screens. Failure to pass the screens will route the Interconnection Application to the Fast Track Process.

3.4. Fast Track Process

An application to interconnect a DER system shall be evaluated under the Fast Track Process if the eligibility requirements are not exceeded in Table 3.2 and the application does not qualify for the Simplified Process. Fast Track eligibility for DERs is determined based upon the generator type, the size of the generator, voltage of the line, and the location and type of line at the Point of Common Coupling, (PCC). All synchronous and induction machines must be no larger than 2 MW to be eligible for Fast Track Process consideration.

Table 3.2. Fast Track Eligibility for DER

Line Voltage	Fast Track Eligibility³ Regardless of Location	Fast Track Eligibility for certified, inverter-based DER on a Mainline⁴ and ≤ 2.5 Electrical Circuit Miles from Substation⁵
< 5 kV	≤ 500 kW	≤ 500 kW
≥ 5 kV and < 15 kV	≤ 1 MW	≤ 2 MW
≥ 15 kV and < 30 kV	≤ 2 MW	≤ 4 MW
≥ 30 kV and ≤ 69 kV	≤ 4 MW	≤ 5 MW

¹ Additional information regarding certified equipment is found in Sections 14 and 15.

² Some PCS may have certification to UL 1741PCS-CRD. This testing guide was withdrawn in 2024. UL 3141 certification is required for PCS beginning in 2026.

³ Synchronous and induction machine eligibility is limited to no more than 2 MW even when line voltage is greater than 15 kV.

⁴ For purposes of this table, a Mainline is the three-phase backbone of a circuit. It will typically constitute lines with wire sizes of 4/0 American wire gauge, 266 kcmil, 336.4 kcmil, 397.5 kcmil, 477 kcmil and 795 kcmil.

⁵ An Interconnection Customer can determine this information about its proposed interconnection location in advance by requesting a pre-application report described in Section 5.

3.5. Study Process

An application to interconnect a DER system that does not meet the Simplified Process or Fast Track Process eligibility requirements or does not pass the review as described in either process, shall be evaluated under the Study Process.

3.6. Non-Export Process

An application to interconnect a DER system that does not export power to the Area EPS and has a nameplate capacity that is less than 100 kW may choose to apply under the Non-Export Process. Examples of DER systems that are configured not to export power may include electric vehicles, emergency power energy storage systems or generators. DER system eligibility screens are listed in the Non-Export Process, Section 3.

3.7. Process Assistance

Prior to submitting an Interconnection Application, the Interconnection Customer may ask the Area EPS Operator's DER Interconnection Coordinator which process track a proposed interconnection is subject to and about additional details regarding each process track.

An Interconnection Customer can obtain, through an informal request, general information about the Interconnection Process and about potentially Affected System(s) for a proposed interconnection at a specific location. The existing electric system information provided to the Interconnection Customer should include relevant system study results, interconnection studies, and other materials useful to an understanding of an interconnection at a particular point on the Area EPS Operator's System. Information will be provided to the extent such provision does not violate the privacy policies of the Area EPS Operator, confidentiality provisions of prior agreements or critical infrastructure requirements. The Area EPS Operator shall comply with reasonable requests for such information.

4 Interconnection Application

4.1. Overview

Each process track has different information that needs to be provided to the Area EPS Operator. Table 4.1 indicates which application is to be completed in its entirety and submitted to the Area EPS Operator to start the interconnection process for the proposed DER system.

Table 4.1. Interconnection Application

Process Track	Application
Simplified	Simplified Interconnection Application
Fast Track	Standard Interconnection Application
Study	Standard Interconnection Application
Non-Export	Non-Export Application

4.2. Availability of Information

The Area EPS Operator will provide all necessary Interconnection Applications, Interconnection Process documents and sample interconnection agreements on its website if possible. If a website is not available, the applicable documents will be readily available at the Area EPS Operator's main office.

The Area EPS Operator will establish a public queue of active interconnection applications on its website once the Area EPS Operator has received at least 40 completed Interconnection Applications in a year. The public queue will be updated, at minimum, on a monthly basis.

4.3. Interconnection Application Process Fees

Each Interconnection Application submitted to the Area EPS Operator must include the appropriate interconnection application process fee prior to the Area EPS Operator reviewing the Interconnection Application. The required process fee for each process track is listed in Table 4.2.

Table 4.2. Interconnection Application Process Fee

Process Track		Process Fee
Simplified		\$125
Fast Track	Certified ⁶ System	\$125 + \$1/kW
	Non-Certified System	\$125 + \$2/kW
Study		\$1,000 + \$2/kW down payment. Additional study fees may apply.
Non-Export		\$0

4.4. Application Review Timelines

The Interconnection Application shall be date- and time-stamped upon initial, and if necessary, resubmission receipt. The Area EPS Operator shall notify the Interconnection Customer if the Interconnection Application is deemed

⁶ Additional information regarding certified equipment is found in Section 14.

incomplete within ten (10) Business Days. This notification shall include a written list detailing all information that must be provided to complete the Interconnection Application.

Depending on the process track the Interconnection Customer has between five (5) and⁵ ten (10) Business Days to provide the missing information unless additional time is requested with valid reasons. Failure to submit the requested information within the stated timeline will result in the Interconnection Application being withdrawn.

An Interconnection Application will be deemed complete upon submission to the Area EPS Operator when all documents, fees and information required with the Interconnection Application adhering to state and local technical requirements are included. The time- and date- stamp of the completed Interconnection Application shall be accepted as the qualifying date for purposes of establishing a queue position as described in Section 4.7.

Depending on the process track the Area EPS Operator has either a total of twenty (20) Business Days or twenty-five (25) Business Days to complete the Interconnection Application review and submit notice back to the Interconnection Customer stating the proposed DER system may proceed with the interconnection process or the proposed DER system requires additional engineering studies. The period of time when waiting for the Interconnection Customer to provide missing information is not included in the Area EPS Operator's twenty (20) Business Days or twenty-five (25) Business Days review timeline.

4.5. Comparability

The Area EPS Operator shall receive, process and analyze all Interconnection Applications in a timely manner. The Area EPS Operator shall use the same Reasonable Efforts in processing and analyzing Interconnection Applications from all Interconnection Customers.

4.6. Changing Process Queues

During the review of the initially submitted Interconnection Application for the proposed DER system, the Area EPS Operator may determine the proposed DER system should be in a different process track. For proposed DER systems that are moved into a different process track after submittal of the initial application, the difference between the originally submitted processing fee and the current process track's processing fee will be assessed. In addition, the Area EPS Operator may request the Interconnection Customer to provide additional information regarding the proposed DER system.

4.7. Queue Position

The Area EPS Operator shall maintain a single, administrative queue and may manage the queue by geographical region. The queue position of each completed Interconnection Application is used to determine the engineering review. The queue position is also used to determine the cost responsibility for system upgrades necessary to accommodate the interconnection.

An Interconnection Application will retain its queue number even when it is moved into a different process track. An Interconnection Application can lose its queue position if the Interconnection Customer misses timelines in the applicable process track. The Interconnection Customer and Area EPS Operator have the opportunity to request timeline extensions which are explained in detail in Section 10.

4.8. Site Control

Documentation of site control must be submitted with the Interconnection Application. Site control may be demonstrated by any of the following:

- Ownership of, a leasehold interest in, or a right to develop a site for the purpose of constructing the DER system.
- An option to purchase or acquire a leasehold site for constructing the DER system.
- An exclusivity or other business relationship between the Interconnection Customer and the entity having the right to sell, lease, or grant to the Interconnection Customer the right to possess or occupy a site for constructing the DER system.

For DER in the Simplified Process, proof of site control may be demonstrated by the site owner's signature on the Simplified Interconnection Application.

5 Pre-Application Report

5.1. Pre-Application Report Requests

The Interconnection Customer may submit a Pre-Application Report Request, including a non-refundable fee of \$300, for a Pre-Application Report on a proposed project at a specific site. The Interconnection Customer must fill out the Pre-Application Request form as completely as possible. The Area EPS Operator shall provide the readily available data listed in Section 5.3 within fifteen (15) Business Days of receipt of a completed request form and payment. The Pre-Application Report produced by the Area EPS Operator is non-binding, does not confer any rights, and does not preclude the Interconnection Customer from any interconnection process steps including submission of the Interconnection Application.

5.2. Information Provided

Using the information provided in the Pre-Application Report Request form, the Area EPS Operator will identify the substation/area bus, bank or circuit likely to serve the proposed PCC. This selection by the Area EPS Operator does not necessarily indicate, after application of the screens and/or study, that this would be the circuit the project ultimately connects to. The Interconnection Customer must request additional Pre-Application Reports if information about multiple PCCs is requested.

The Pre-Application Report will only include existing data. A request for a Pre-Application Report does not obligate the Area EPS Operator to conduct a study or other analysis of the proposed DER in the event that data is not readily available. The Area EPS Operator will provide the Interconnection Customer with the data that is available. The confidentiality provisions in Section 12.1 apply to Pre-Application Reports.

5.3. Pre-Application Report Components

The Pre-Application Report shall include the following pieces of information provided the data currently exists and is readily available.

- Total capacity (in megawatts (MW)) of substation/area bus, bank or circuit based on normal or operating ratings likely to serve the proposed Point of Common Coupling.
- Existing aggregate generation capacity (in MW) interconnected to a substation/area bus, bank or circuit (i.e., amount of generation online) likely to serve the proposed Point of Common Coupling.
- Aggregate queued generation capacity (in MW) for a substation/area bus, bank or circuit (i.e., amount of generation in the queue) likely to serve the proposed Point of Common Coupling.
- Available capacity (in MW) of substation/area bus or bank and circuit likely to serve the proposed Point of Common Coupling (i.e., total capacity less the sum of existing aggregate generation capacity and aggregate queued generation capacity).
- Substation nominal distribution voltage and/or transmission nominal voltage if applicable.
- Nominal distribution circuit voltage at the proposed Point of Common Coupling.
- Approximate circuit distance between the proposed Point of Common Coupling and the substation.

- Relevant line section(s) actual or estimated peak load and minimum load data, including daytime minimum load and absolute minimum load, when available.
Whether the Point of Common Coupling is located behind a line voltage regulator.
- Number and rating of protective devices and number and type (standard, bi-directional) of voltage regulating devices between the proposed Point of Common Coupling and the substation/area. Identify whether the substation has a load tap changer.
- Number of phases available on the Area EPS medium voltage system at the proposed Point of Common Coupling. If a single phase, distance from the three-phase circuit.
- Limiting conductor ratings from the proposed Point of Common Coupling to the distribution substation.
- Whether the Point of Common Coupling is located on a spot network, grid network, or radial supply.
- Based on the proposed Point of Common Coupling, existing or known constraints such as, but not limited to, electrical dependencies at that location, short circuit interrupting capacity issues, power quality or stability issues on the circuit, capacity constraints, or secondary networks.

6 Capacity of the Distributed Energy Resources

6.1. Existing DER System Expansion

If the Interconnection Application is for an increase in capacity to an existing DER system, the Interconnection Application shall be evaluated on the basis of the total new alternating current (AC) Capacity Rating of the existing and proposed DER units. The maximum capacity for the DER system is determined by the aggregated production capability for the DER units that make up the combined DER system without incorporating electric load of the service.

6.2. New DER Systems

An Interconnection Application for a DER that includes multiple energy production devices, (i.e. solar and storage), at a site for which the Interconnection Customer seeks a simple Point of Common Coupling, shall be evaluated on the basis of the DER system's Capacity Rating. The DER capacity is determined by the aggregated production capability for the DER units that make up the DER system without incorporating electric load of the service.

6.3. Export Capacity of the DER System

A DER system may include devices, (i.e. control systems, power relays or other similar device settings), that can limit the DER system's Export Capacity causing it to be different from the DER system's Capacity Rating. Limiting the Export Capacity of a DER system is a potential method to avoid distribution infrastructure updates that would otherwise be required when interconnecting the maximum capacity of the DER system.

For DER system that includes Export Capacity limiting devices, the Interconnection Customer must obtain the Area EPS Operator's agreement to consider the DER system with an Export Capacity rating that is less than the DER system's Capacity Rating identified in section 6.1 or 6.2. Acceptable methods for limiting the Export Capacity of a DER system are listed in Section 6.4.

6.4 Acceptable Methods for Establishing Capacity Rating of a DER System

Acceptable Methods to establish the Capacity Rating of a DER system measured at the Point of DER Connection (PoC) are listed below. Additional details regarding the Area EPS Operator's approval of the proposed method are described in section 6.6. The use of the electric service's load to establish the Capacity Rating of a DER is not acceptable.

- The use of the Nameplate Rating of the DER system as the Capacity Rating.
- Certified Inverters: The DER system only uses certified inverters that are programmed to allow a limited capacity below the Nameplate Capacity of the inverter. A copy of the inverter settings limiting the capacity values is required at the time of application.
- Certified Power Control System (PCS): Installed Power Control System that will measure the inflow of power from different DER units and trip the DER system if limits are not maintained. Power Control Systems must meet the requirements listed in state and local technical requirements.

6.5 Acceptable Methods for Establishing Export Capacity of a DER System

Acceptable methods for establishing the Export Capacity of a DER system are listed below. The use of the electric service's load to limit Export Capacity of a DER is not acceptable.

- The use of the Nameplate Rating of the DER system as the Export Capacity
- The use of the Capacity Rating of the DER system as the Export Capacity when approved by the Area EPS Operator.

- Reverse-Power Protection Device: Installed device that will measure any export of power and trip the DER system or open an inter-tie breaker to isolate the DER system if limits are exceeded. Require sensitivity levels of devices are listed in state technical requirements.
- Certified Power Control System (PCS): Installed Power Control System that will measure the inflow of power and trip the DER system if limits are not maintained. Power Control Systems must meet the requirements listed in the state technical requirements.
- Certified Inverters: The DER system only uses certified inverters that are programed to allow a limited capacity below the nameplate of the inverter. A copy of the inverter settings limiting the capacity values is required at the time of application.

6.6 Area EPS Operator Approval of Modified Capacity

If the Capacity Rating and/or the Export Capacity is different than the aggregate Nameplate Rating of the DER system, the Interconnection Customer shall complete the Modified Capacity of a DER system supplemental form in conjunction with the appropriate interconnection application for proposed DER system. This information will be used by the Area EPS Operator when performing the initial review screens.

Additional methods to establish the Capacity Rating and/or Export Capacity that are different from the Nameplate Rating may be proposed to the Area EPS Operator for review and approval. The Area EPS Operator's agreement, recognizing the Capacity Rating and/or Export Capacity that is different from the Nameplate Rating, shall not be unreasonably withheld, provided proper documentation demonstrating the method established to modify the capacity term meets the Area EPS Operator's Technical Requirements. If the Area EPS Operator does not agree the method or documentation meets state and Area EPS technical requirements, the Interconnection Application must be withdrawn or revised to specify the Nameplate Rating as the DER system's Capacity Rating and Export Capacity. Nothing in this section shall prevent the Area EPS Operator from considering a higher capacity if the limitations do not provide adequate assurance when evaluating impacts to the Area EPS.

7 Modification to Interconnection Applications

7.1. Procedures

At any time after the Interconnection Application is deemed complete, the Interconnection Customer or the Area EPS Operator may identify modifications to the proposed DER system that may improve costs and benefits (including reliability) of the proposed DER system and the ability for the Area EPS Operator to accommodate the proposed DER system. The Interconnection Customer shall submit to the Area EPS Operator in writing all proposed

modifications to any information provided in the Interconnection Application. The Area EPS Operator cannot unilaterally modify the Interconnection Application.

Additional information regarding modifications to interconnection applications is found in each process track document.

8 Interconnection Agreements

8.1. Timelines

After the Interconnection Application has been approved by the Area EPS Operator, the Area EPS Operator shall provide the Interconnection Customer with an executable Interconnection Agreement within five (5) Business Days. The Interconnection Customer shall have thirty (30) Business Days to sign and return the Interconnection Agreement to the Area EPS Operator. The Area EPS Operator shall sign the Interconnection Agreement within five (5) business days after receiving the signed Interconnection Agreement from the Interconnection Customer. If the Interconnection Customer fails to return a signed Interconnection Agreement to the Area EPS Operator within thirty (30) Business Days and fails to request an extension as explained in Section 10, the Interconnection Application will be deemed withdrawn.

8.2. Types of Agreements

There are two main types of Interconnection Agreements that may be executed with an approved Interconnection Application. In general, Interconnection Customers with a proposed DER system that qualifies for the Simplified Process or the Non-Export Process will sign the Area EPS Operator's Uniform Contract. Proposed DER systems less than 100 kW that are under the Fast Track Process may also sign the Uniform Contract. All other sized DER system will sign the Municipal Minnesota Interconnection Agreement (MMIA). Area EPS Operators who do not purchase the excess generation of the proposed DER system will also require the MMIA to be executed for any size of DER system.

Table 8.1. Interconnection Agreements

Process Track		Interconnection Agreement
Simplified		Uniform Contract
Fast Track	Qualifies for net energy billing	Uniform Contract
	Less than 100 kW and Area EPS agrees to purchase excess generation	Uniform Contract
	All other DER systems	MMIA
Study		MMIA
Non-Export	Extended parallel	Uniform Contract
	Backup only	None

Interconnection Customers may choose to sign the MMIA in lieu of the Uniform Contract. A separate power purchase agreement will also need to be executed if the Uniform Contract is not utilized. Interconnection of the proposed DER system will not occur until a signed Uniform Contract or the MMIA is returned to the Area EPS Operator within thirty (30) Business Days of receipt of the MMIA or Uniform Contract and no later than five (5) days prior to scheduled testing and inspection.

9 Interconnection

9.1. Metering

Any metering requirements necessitated by the use of the DER system shall be installed at the Interconnection Customer's expense. The metering requirement costs will be included in the final invoice of interconnection costs to the Interconnection Customer. The Interconnection Customer is also responsible for metering replacement costs not covered in the Interconnection Customer's general customer charge. The Area EPS Operator may charge Interconnection Customers an ongoing metering-related charge for an estimate of ongoing metering-related costs specifically demonstrated.

9.2. Inspection, Testing and Commissioning

In alignment with the Area EPS Operator's technical requirements, the Area EPS Operator shall publicly publish their required DER technical settings. The settings file is typically called the Area EPS Operator's Utility Required Profile—Specified Settings (URP—SS).

Upon completing construction of the DER system, the Interconnection Customer will cause the DER system to be inspected or otherwise certified by the appropriate local electrical wiring inspector with jurisdiction. The interconnection Customer shall then arrange for the inspection and testing of the DER system and the Customer's Interconnection Facilities prior to interconnection pursuant to the Area EPS Operator's technical requirements. Commissioning tests of the Interconnection Customer's installed equipment shall be performed pursuant to Local Technical Requirements.

The Interconnection Customer shall notify the Area EPS Operator of testing and inspection no fewer than five (5) Business Days in advance, or as may be agreed to by the Parties. Depending on the process track, either a Certificate of Completion or a testing procedure shall be submitted to the Area EPS Operator prior to the testing and inspection date. For all process tracks, the Interconnection Customer shall supply a copy of the settings programmed into the DER system in the .csv format of the Utility Required Profile—Applied Settings (URP—AS). Additional details about the URP—SS and URP—AS are listed in State and Local Technical Requirements.

The Area EPS Operator shall send qualified personnel to the DER site to inspect the interconnection and witness the testing. Testing and inspection shall occur on a Business Day at a mutually agreed upon time and date. The Area EPS Operator may waive the right to witness the testing.

9.3. Interconnection Costs

The Interconnection Customer shall pay for the actual cost of the Interconnection Facilities and Distribution Upgrades along with the Area EPS Operator's cost to commission the proposed DER system. An estimate of the interconnection costs shall be stated in the Uniform Contract or MMIA.

9.4. Technical Requirements

The Area EPS Operator shall use Reasonable Efforts to provide the Interconnection Customer with its Local Technical Requirements in the form of a Technical Specifications Manual (TSM) by providing the document with the notice of approval of the interconnection application or by providing a website link to the document. Additionally, the Area EPS Operator shall notify the Interconnection Customer of any changes to these requirements as soon as they are known. Unless notified by the Area EPS Operator, the Interconnection Customer only needs to be in compliance with the version of the Area EPS Operator's TSM current at the time of interconnection.

9.5. Authorization for Parallel Operations

The Interconnection Customer shall not operate its DER system in parallel with the Area EPS Operator's distribution system without prior written authorization from the Area EPS Operator. The Area EPS Operator shall provide such authorization within three (3) Business Days from when the Area EPS Operator receives notification that the Interconnection Customer has complied with all applicable parallel operations requirements; the completion of a successful testing and inspection of the DER system and all payments for issued bills related to the interconnection process that are past due have been paid in full. Such authorization shall not be unreasonably withheld, conditioned or delayed.

9.6. Non-Compliance with Agreements

If it is discovered that the DER system is in non-compliance with the executed agreement with the Area EPS Operator, the Area EPS Operator may disconnect the DER system from the Area EPS. Non-compliance includes discovery that the DER system is generating at a greater power capacity than stated in the agreement. Upon discovery of this non-compliance issue, the Area EPS Operator will provide written notice to the Interconnection Customer of the non-compliance and request the Interconnection Customer remedy the problem prior to reconnection of the DER system. If the capacity of the DER system has

changed, a new interconnection application will be required to be submitted to the Area EPS Operator. Prior to reconnection of the existing DER system, a witness test is required at the Interconnection Customer's expense. The witness test may be waived by the Area EPS Operator. Non-compliant DER systems that could cause harm to the public or utility personnel or cause damage to the Area EPS may be disconnected from the Area EPS without advance notice to the Interconnection Customer.

10 Extension of Timelines

10.1. Reasonable Efforts

The Area EPS Operator shall make Reasonable Efforts to meet all time frames provided in these procedures. If the Area EPS Operator cannot meet a deadline provided herein, it must notify the Interconnection Customer in writing within three (3) Business Days after the deadline to explain the reason for the failure to meet the deadline and provide an estimated time by which it will complete the applicable interconnection procedure in the process.

10.2. Extensions

For applicable time frames described in these procedures, the Interconnection Customer may request, in writing, one extension equivalent to half of the time originally allotted (e.g., ten (10) Business Days for a twenty (20) Business Days original time frame) which the Area EPS Operator may not unreasonably refuse. No further extensions for the applicable time frame shall be granted absent a Force Majeure Event or other similarly extraordinary circumstance.

11 Disputes

11.1. Procedures

The Parties agree to make good faith efforts to attempt to resolve all disputes arising out of the interconnection process and associated study and Interconnection Agreements. The Parties agree to follow the established dispute resolution policy adopted by the Area EPS Operator.

12 Clauses

12.1. Confidentiality

Confidential Information shall mean any confidential and/or proprietary information provided by one Party to the other Party that is clearly marked or otherwise designated "Confidential." For purposes of these procedures, design, operating specifications, and metering data provided by the Interconnection Customer may be deemed Confidential Information regardless of whether it is clearly marked or otherwise designated as such. If requested by either Party, the other Party shall provide in writing the basis for asserting that the information warrants confidential treatment. Parties providing a Governmental

Authority trade secret, or privileged or otherwise not public or nonpublic data under Minnesota Government Data Practices Act, Minnesota Statutes Chapter 13, shall identify such data consistent with the Commission's September 1, 1999 Revised Procedures for Handling Trade Secret and Privileged Data.

Confidential Information does not include information previously in the public domain with proper authorization, required to be publicly submitted or divulged by Governmental Authorities (after notice to the other Party and after exhausting any opportunity to oppose such publication or release), or necessary to be publicly divulged in an action to enforce these procedures. Each Party receiving Confidential Information shall hold such information in confidence and shall not disclose it to any third party nor to the public without prior written authorization from the Party providing that information, except to fulfill obligations under these procedures, or to fulfill legal or regulatory requirements that could not otherwise be fulfilled by not making the information public.

Each Party shall hold in confidence and shall not disclose Confidential Information, to any person (except employees, officers, representatives and agents, who agree to be bound by this section). Confidential Information shall be clearly marked as such on each page or otherwise affirmatively identified. If a court, government agency or entity with the right, power, and authority to do so, requests or requires either Party, by subpoena, oral disposition, interrogatories, requests for production of documents, administrative order, or otherwise, to disclose Confidential Information, that Party shall provide the other Party with prompt notice of such request(s) or requirements(s) so that the other Party may seek an appropriate protective order or waive compliance with the terms of this Agreement. In the absence of a protective order or waiver the Party shall disclose such confidential information which, in the opinion of its counsel, the party is legally compelled to disclose. Each Party will use reasonable efforts to obtain reliable assurance that confidential treatment will be accorded to any confidential information furnished.

Critical infrastructure information or information that is deemed or otherwise designated by a Party as Critical Energy/Electric Infrastructure Information (CEII) pursuant to FERC regulation, [18 C.F.R. §388.133](#), as may be amended from time to time, may be subject to further protections for disclosure as required by FERC or FERC regulations or orders and the disclosing Party's CEII policies. Each Party shall employ at least the same standard of care to protect Confidential Information obtained from the other Party as it employs to protect its own Confidential Information.

Each Party is entitled to equitable relief, by injunction or otherwise, to enforce its rights under this provision to prevent the release of Confidential Information

without bond or proof of damages and may seek other remedies available at law or in equity for breach of this provision.

12.2. Non-Warranty

The Area EPS Operator does not give any warranty, expressed or implied, as to the adequacy, safety, or other characteristics of any structures, equipment, wires, appliances or devices owned, operated, installed or maintained by the Interconnection Customer, including without limitation the DER and any structures, equipment, wires, appliances or devices not owned, operated or maintained by the Area EPS Operator.

The Area EPS Operator does not guarantee uninterrupted power supply to the DER and will operate the Distribution System with the same reliability standards for the entire customer base.

12.3. Indemnification

Each Party is protected from liability incurred to third parties as a result of carrying out the provisions of this interconnection process and subsequent interconnection agreements. The Parties shall at all times indemnify, defend, and save the other Party harmless from, any and all damages, losses, claims, including claims and actions relating to injury to or death of any person or damage to property, demand, suits, recoveries, costs and expenses, court costs, attorney fees, and all other obligations by or to third parties, arising out of or resulting from the other Party's action or inactions of its obligations under this agreement on behalf of the indemnifying Party, except in cases of gross negligence or intentional wrongdoing by the indemnified Party.

This indemnification obligation shall apply notwithstanding any negligent or intentional acts, errors or omissions of the indemnified Party, but the indemnifying Party's liability to indemnify the indemnified Party shall be reduced in proportion to the percentage by which the indemnified Party's negligent or intentional acts, errors or omissions caused the damages.

Neither Party shall be indemnified for its damages resulting from its sole negligence, intentional acts or willful misconduct. These indemnity provisions shall not be construed to relieve any insurer of its obligation to pay claims consistent with the provisions of a valid insurance policy.

If an indemnified person is entitled to indemnification under this article as a result of a claim by a third party, and the indemnifying Party fails, after notice and reasonable opportunity to proceed under this article, to assume the defense of such claim, such indemnified person may at the expense of the indemnifying Party contest, settle or consent to the entry of any judgment with respect to, or pay in full, such claim.

If an indemnifying party is obligated to indemnify and hold any indemnified person harmless under this article, the amount owing to the indemnified person shall be the amount of such indemnified person's actual loss, net of any insurance or other recovery.

Promptly after receipt by an indemnified person of any claim or notice of the commencement of any action or administrative or legal proceeding or investigation as to which the indemnity provided for in this article may apply, the indemnified person shall notify the indemnifying party of such fact. Any failure of or delay in such notification shall not affect a Party's indemnification obligation unless such failure or delay is materially prejudicial to the indemnifying party.

12.4. Limitation of Liability

Each party's liability to the other party for any loss, cost, claim, injury, liability, or expense, including reasonable attorney's fees, relating to or arising from any act or omission in its performance of this Agreement, shall be limited to the amount of direct damage actually incurred. In no event shall either party be liable to the other party for an indirect, incidental, special, consequential, or punitive damages of any kind whatsoever, except as allowed under in Section 12.3.

13 Glossary

Affected System – Another Area EPS Operator’s System, Transmission Owner’s Transmission System, or Transmission System connected generation which may be affected by the proposed interconnection.

Applicant Agent – A person designated in writing by the Interconnection Customer to represent or provide information to the Area EPS on the Interconnection Customer’s behalf throughout the interconnection process.

Area EPS – The electric power distribution system connected at the Point of Common Coupling (i.e., the local utility’s electric distribution system, or “grid.”).

Area EPS Operator – An entity that owns, controls, or operates the electric power distribution systems that are used for the provision of electric service in Minnesota (i.e., the local electrical utility grid operator).

Business Day – Monday through Friday, excluding Holidays as defined by Minn. Stat. §645.44, Subdivision 5. Any communication to have been sent or received after 4:30 p.m. Central Prevailing Time or on a Saturday, Sunday or holiday shall be considered to have been sent on the next Business Day.

Capacity Rating – The total number of kilowatts a DER system is maximally capable of producing. The Capacity Rating may be a lesser value than the Nameplate Rating provided the conditions in Section 6 are met, and the Interconnection Customer obtains the Area EPS Operator’s approval. The Capacity Rating referred to in the M-MIP is the alternating current DER rating at the Point of DER Connection (PoC) or, if applicable, the aggregate DER ratings for multiple DER units at their points of DER Connection. Its determination does not include any reduction accounting for the load served by the DER.

Certified Equipment – Equipment that has been tested by a nationally recognized lab meeting a specific standard. For DER systems, a UL 1741 listing is a common form of DER inverter certification. Additional information is contained in Section 14.

Confidential Information – Any confidential and/or proprietary information provided by one Party to the other Party and is clearly marked or otherwise designated “Confidential.” All procedures, design, operating specifications, and metering data provided by the Interconnection Customer may be deemed Confidential Information. See Section 12.1 for further information.

Distributed Energy Resource (DER) – A source of electric power that is not directly connected to a bulk power system or central station service. DER includes both generators and energy storage technologies capable of exporting active power to an Area EPS. An interconnection system or a supplemental DER device that is necessary for compliance with this standard is part of a DER. For the purpose of the Interconnection Process and interconnection agreements, the DER includes the Customer’s Interconnection Facilities but shall not include the Area EPS Operator’s Interconnection Facilities.

Distribution System – The Area EPS facilities which are not part of the Local EPS, Transmission System or any generation system.

Distribution Upgrades – The additions, modifications, and upgrades to the Distribution System at or beyond the Point of Common Coupling to facilitate interconnection of the DER and render the distribution service necessary to effect the Interconnection Customer's connection to the Distribution System. Distribution Upgrades do not include Interconnection Facilities.

Electric Power System (EPS) – The facilities that deliver electric power to a load.

Fast Track Process – The procedure for evaluating an Interconnection Application for a DER that meets the eligibility requirements of Section 3.4.

Force Majeure Event – An act of God, labor disturbance, act of the public enemy, war, insurrection, riot, fire, storm or flood, explosion, breakage or accident to machinery or equipment, an order, regulation or restriction imposed by governmental, military or lawfully established civilian authorities, or another cause beyond a Party's control. A Force Majeure Event does not include an act of negligence or intentional wrongdoing.

Good Utility Practice – Any of the practices, methods and acts engaged in or approved by a significant portion of the electric industry during the relevant time period, or any of the practices, methods and act which, in the exercise of reasonable judgment in light of the facts known at the time the decision was made, could have been expected to accomplish the desired result at a reasonable cost consistent with good business practices, reliability, safety and expedition. Good Utility Practice is not intended to be limited to the optimum practice, method, or act to the exclusion of all others, but rather to be acceptable practices, methods, or acts generally accepted in the region.

Governmental Authority – Any federal, state, local or other governmental regulatory or administrative agency, court, commission, department, board, or other governmental subdivision, legislature, rulemaking board, tribunal, or other governmental authority having jurisdiction over the Parties, their respective facilities, or the respective services they provide, and exercising or entitled to exercise any administrative, executive, police, or taxing authority or power; provided, however, that such term does not include the Interconnection Customer, the Area EPS Operator, or any Affiliate thereof. The governing authority of the municipal utility is the authority governing interconnection requirements unless otherwise provided for in State Technical Requirements.

Interconnection Agreement – The terms and conditions between the Area EPS Operator and Interconnection Customer (Parties). See Section 8 for when the Uniform Contract or Municipal Minnesota Interconnection Agreement applies.

Interconnection Application – The Standard or Simplified Interconnection Application, as applicable, pursuant to Section 4.

Interconnection Customer – The person or entity named on the electric utility bill for a premise who owns and proposes to interconnect a DER on that premises with the Area

EPS Operator's Distribution System. The Interconnection Customer is responsible for ensuring the DERs designed, operated and maintained in compliance with State and Local Technical Requirements.

Interconnection Facilities – The Area EPS Operator's Interconnection Facilities and the Interconnection Customer's Interconnection Facilities. Collectively, Interconnection Facilities include all facilities and equipment between the DER and the Point of Common Coupling, including any modification, additions or upgrades that are necessary to physically and electrically interconnect the DER to the Area EPS Operator's System. Some examples of Customer Interconnection Facilities include supplemental DER devices, inverters, and associated wiring and cables up to the Point of DER Connection. Some examples of Area EPS Operator Interconnection Facilities include sole use facilities; such as, line extensions, controls, relays, switches, breakers, transformers and shall not include Distribution Upgrades or Network Upgrades.

Interconnection Process – All of the information encompassed in the booklets and forms in the Minnesota Municipal Interconnection Process (M-MIP).

Local Technical Requirements – The requirements contained in the Technical Specifications Manual (TSM) of the Area EPS Operator.

Material Modification – A modification to machine data, equipment configuration or to the interconnection site of the DER at any time after receiving notification by the Area EPS Operator of a complete Interconnection Application that has a material impact on the cost, timing, or design of any Interconnection Facilities or Upgrades, or a material impact on the cost, timing or design of any Interconnection Application with a later Queue Position or the safety or reliability of the Area EPS.⁷

Nameplate Rating – Nominal voltage (V), current (A), maximum active power (kWac), apparent power (kVA), and reactive power (kVar) at which a DER is capable of sustained operation. For a Local EPS with multiple DER units, the aggregate nameplate rating is equal to the sum of all DERs nameplate rating in the Local EPS. For purposes of Attachment 5 in the MMIA, the DER system's Nameplate Rating may, with the Area EPS Operator's agreement, be replaced with the DER system's Capacity Rating,

⁷ A Material Modification shall include, but may not be limited to, a modification from the approved Interconnection Application that: (1) changes the physical location of the point of common coupling such that it is likely to have an impact on technical review; (2) increases the nameplate rating or output characteristics of the Distributed Energy Resource; (3) changes or replaces generating equipment, such as generator(s), inverter(s), transformers, relaying, controls, etc., and substitutes equipment that is not like-kind substitution in certification, size, ratings, impedances, efficiencies or capabilities of the equipment; (4) changes transformer connection(s) or grounding; and/or (5) changes to a certified inverter with different specifications or different inverter control settings or configuration. A Material Modification shall not include a modification from the approved Interconnection Application that: (1) changes the ownership of a Distributed Energy Resource; (2) changes the address of the Distributed Energy Resource, so long as the physical point of common coupling remains the same; (3) changes or replaces generating equipment such as generator(s), inverter(s), solar panel(s), transformers, relaying, controls, etc. and substitutes equipment that is a like-kind substitution in certification, size, ratings, impedances, efficiencies or capabilities of the equipment; and/or (4) increases the DC/AC ratio but does not increase the maximum AC output capability of the Distributed Energy Resource in a way that is likely to have an impact on technical review

provided the Nameplate Rating is reduced through use of control systems, power relays or similar device settings or adjustments as identified in IEEE 1547. The Nameplate Ratings referenced in the Interconnection Process are alternating current nameplate DER ratings at the Point of DER Connection (PoC).

Network Upgrades – Additions, modifications, and upgrades to the Transmission System required at or beyond the point at which the DER interconnects with the Area EPS Operator’s System to accommodate the interconnection with the DER to the Area EPS Operator’s System. Network Upgrades do not include Distribution Upgrades.

Operating Requirements – Any operating and technical requirements that may be applicable due to the Transmission Provider’s technical requirements or Minnesota Technical Requirements, including those set forth in the Interconnection Agreement.

Party or Parties – The Area EPS Operator and the Interconnection Customer.

Point of Common Coupling (PCC) – The point where the Interconnection Facilities connect with the Area EPS Operator’s Distribution System. See figure 1. Equivalent, in most cases, to “service point” as specified by the Area EPS Operator and described in the National Electrical Code and the National Electrical Safety Code.

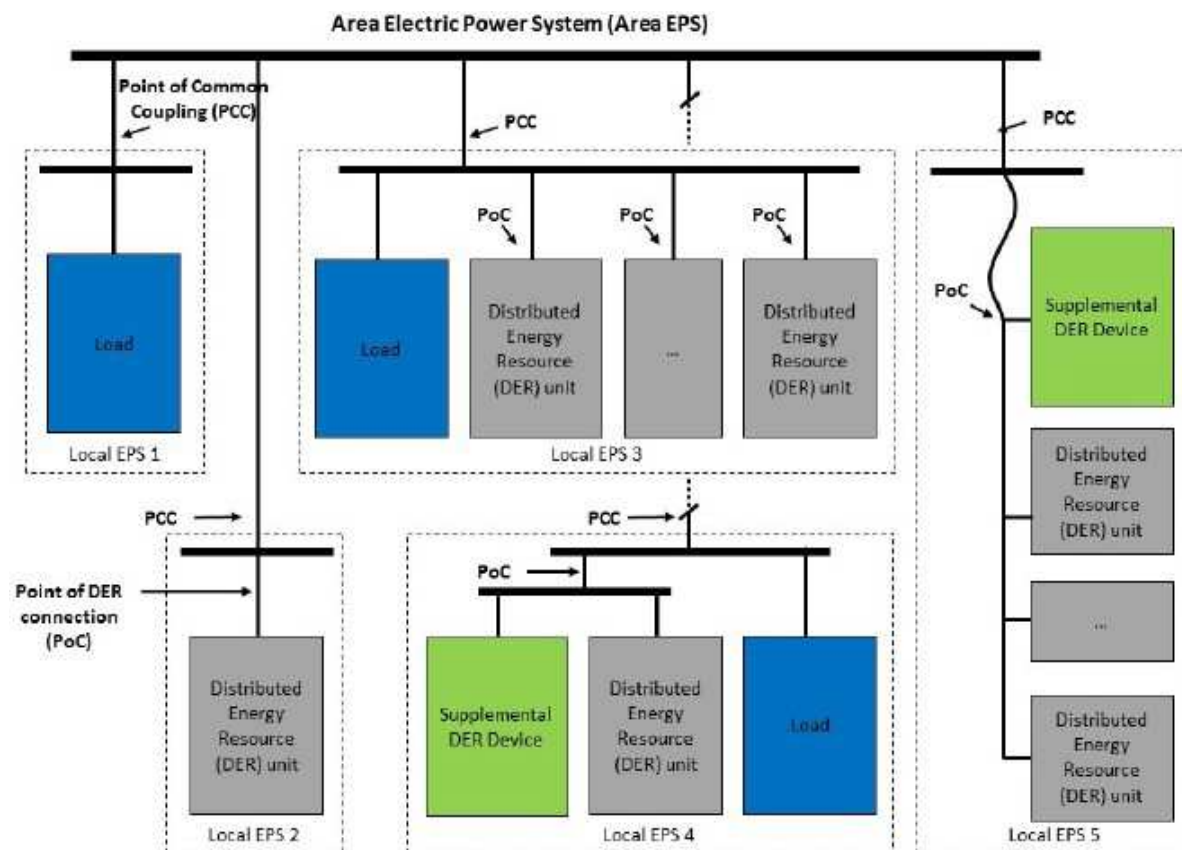

Figure 1: Point of Common Coupling and Point of DER Connection (Source: IEEE 1547)

Point of DER Connection (PoC) – When identified as the Reference Point of Applicability, the point where an individual DER is electrically connected in a Local EPS and meets the requirements of this standard exclusive of any load present in the respective part of the Local EPS (e.g., terminals of the inverter when no supplemental DER device is required). For DER unit(s) that are not self-sufficient to meet the requirements without a supplemental DER device(s), the Point of DER Connection is the point where the requirements of this standard are met by DER in conjunction with a supplemental DER device(s) exclusive of any load present in the respective part of the Local EPS.

Queue Position – The order of a valid Interconnection Application, relative to all other pending valid Interconnection Applications, that is established based upon the date- and time- of receipt of the complete Interconnection Application as described in Section 4.7.

Reasonable Efforts – With respect to an action required to be attempted or taken by a Party under these procedures, efforts that are timely and consistent with Good Utility Practice and are otherwise substantially equivalent to those a Party would use to protect its own interests.

Reference Point of Applicability – The location, either the Point of Common Coupling or the Point of DER Connection, where the interconnection and interoperability performance requirements specified in IEEE 1547 apply. With mutual agreement, the Area EPS Operator and Customer may determine a point between the Point of Common Coupling and Point of DER Connection. See State Technical Requirements for more information.

Simplified Process – The procedure that only uses initial screens for evaluating an Interconnection Application for a certified inverter-based DER no larger than 20 kW.

State Technical Requirements – The Minnesota Technical Interconnection and Interoperability Requirements (TIIR) as adopted by the Minnesota Public Utilities Commission on January 22, 2022 as part of Docket No. E-999/CI-16-521 and as updated thereafter.

Study Process – The procedure for evaluating an Interconnection Application that includes the scoping meeting, system impact study, and facilities study.

Transmission Owner – The entity that owns, leases or otherwise possesses an interest in the portion of the Transmission System relevant to the Interconnection.

Transmission Provider – The entity (or its designated agent) that owns, leases, controls, or operates transmission facilities used for the transmission of electricity. The term Transmission Provider includes the Transmission Owner when the Transmission Owner is separate from the Transmission Provider. The Transmission Provider may include the Independent System Operator or Regional Transmission Operator.

Transmission System – The facilities owned, leased, controlled or operated by the Transmission Provider or the Transmission Owner that are used to provide transmission

service. See the Commission's July 26, 2000 Order Adopting Boundary Guidelines for Distinguishing Transmission from Generation and Distribution Assets in Docket No. E-999/CI-99-1261.

Uniform Contract – The Area EPS Operator's agreement form for Cogeneration and Small Power Production Facilities that may be applied to all qualifying new and existing interconnections between the Area EPS Operator and a DER system having capacity less than 40 kilowatts.

Upgrades – The required additions and modifications to the Area EPS Operator's Transmission or Distribution System at or beyond the Point of Interconnection. Upgrades may be Network Upgrades or Distribution Upgrades. Upgrades do not include Interconnection Facilities.

14 Certification of DER Equipment

Distributed Energy Resource (DER) equipment proposed for use in an interconnection system shall be considered certified for interconnected operation if the following criteria is met:

- 1) It has been tested in accordance with industry standards for continuous utility interactive operation in compliance with the appropriate codes and standards referenced below by any Nationally Recognized Testing Laboratory (NRTL) recognized by the United States Occupational Safety and Health Administration to test and certify interconnection equipment pursuant to the relevant codes and standards listed in the Overview Process,
- 2) It has been labeled and is publicly listed by such NRTL at the time of the interconnection application, and
- 3) Such NRTL makes readily available for verification all test standards and procedures it utilized in performing such equipment certification, and, with consumer approval, the test data itself. The NRTL may make such information available on its website and by encouraging such information to be included in the manufacturer's literature accompanying the equipment.

The Interconnection Customer must verify that the assembly and use of the equipment falls within the use or uses for which the equipment was tested, labeled, and listed by the NRTL.

Certified equipment shall not require further type-test review, testing, or additional equipment to meet the requirements of this interconnection procedure; however, nothing herein shall preclude the need for a DER Design Evaluation or an on-site commissioning test by the parties to the interconnection as provided for in the State Technical Requirements.

If the certified equipment package includes only interface components (switchgear, inverters, or other interface devices), then an Interconnection Customer must show that the generator or other electric source being utilized with the equipment package is compatible with the equipment package and is consistent with the testing and listing specified for this type of interconnection equipment.

Provided the generator or electric source, when combined with the equipment package, is within the range of capabilities for which it was tested by the NRTL and does not violate the interface components' labeling and listing performed by the NRTL, no further type-test review, testing or additional equipment on the customer side of the Point of Common Coupling shall be required to be considered certified for the purposes of this interconnection procedure; however, nothing herein shall preclude the need for a DER design evaluation or an on-site commissioning test by the parties to the interconnection as provided for in State Technical Requirements.

An equipment package does not include equipment provided by the Area EPS.

15 Interconnection Process Milestones

